

Board Policy No. 624

SUBJECT: Alternate Energy Production

I. PURPOSE

To permit Alternative Energy System (AES)/Qualifying Facility (QF) Owners to operate cogeneration and small power production facilities and safely and reliably interconnect them with the Cooperative's electric distribution system.

II. CONTENT

The term AES/QF shall be used throughout this document to define any form of generation that is not owned and operative by the Cooperative, and is interconnected with the Cooperative. Alternative Energy Systems are defined under Pennsylvania's Alternative Energy Portfolio Standard Act of 2004 (Act 213-004). Qualifying Facilities are defined under the Public Utility Regulatory Policies Act of 1978 (PURTA). This policy will enable the AES/QF Owner to deliver total or excess energy into the Cooperative's distribution system. Compensation for such delivered energy shall be based on Allegheny's avoided costs. The interconnection of an AES/QF and the Cooperative's distribution system is subject to the following conditions:

- A. If the AES/QF has nondiscriminatory access to one of the following: (1) independently administered, action-based day ahead and real time energy markets and wholesale markets for long-term capacity sales, or (2) an open access transmission and interconnection service provided by FERC-approved regional transmission organization and competitive wholesale markets that provide an opportunity to sell capacity and energy, then Allegheny's obligation to purchase the energy and capacity generated by an AES/QF may be waived by petitioning FERC for relief from the obligation to purchase energy and capacity on a service territory-wide basis by demonstrating that options (1) or (2) are available to the AES/QF.
- B. Prior to the time of interconnection, the AES/QF Owner must submit to the Cooperative complete and detailed electrical drawings, signed by a licensed Pennsylvania Professional Engineer of the AES/QF. Such submittal shall be in sufficient detail to provide reasonable assurance that the AES/QF complies with all Cooperative and Allegheny requirements. Any new or proposed AES/QF should be evaluated by the Cooperative to determine system impacts. The AES/QF Owner shall provide the Cooperative with appropriate documentation evidencing satisfactory level of completion when the unit is ready to be energized. Written

approval must be received from the Cooperative prior to the physical interconnection of the AES/QF to the Cooperative's electric system. The *SAFETY & INTERCONNECTION REQUIREMENTS FOR ALTERNATE ENERGY PRODUCTION* documentation is a supplement to this policy and provides additional details regarding the evaluation of proposed generators.

The AES/QF Owner shall be responsible for payment of any incremental costs incurred by the Cooperative or Allegheny to interconnect with, synchronize, or accept output from the AES/QF. This would include, but not be limited to:

1. The costs associated with an engineering or evaluation study to accommodate the AES/QF interconnection.
2. Increase in transformer capacity and service conductor size or length.
3. Change or addition of type of service: e.g.
 - a. Single-phase to three-phase
 - b. Voltage change (120/240 to 240/480, etc.)
 - c. Metering or disconnect devices
4. Line extension or system upgrade for an AES/QF
 - a. Single-phase line extension to the facility
 - b. Three-phase line extension to the facility
 - c. Reconductoring a circuit to increase current carrying capability
 - d. Changes to existing Cooperative protection schemes, including associated communications.
 - e. Changes to existing Cooperative voltage regulating schemes, including associated communications

All AES/QF wiring must be in compliance with the National Electrical Code (NEC) and all other applicable codes and ordinances, and must be approved by an electric inspection agency acceptable to the Cooperative. Proper grounding is imperative in ensuring safe operation. The latest editions of NEC Article 250 and IEEE Green Book ANSI C114.1-1973/IEEE 142-1972 should be referenced.

Any reference in this Policy to a code, standard, regulation, or guideline shall be construed to mean the then-current version of that document.

- C. The interconnection equipment must be of a “fail safe” design to ensure, in the event of any electrical supply or equipment failure, that the AES'/AF's and the Cooperative's electric system will be physically separated automatically. To prevent islanding on specific AES/QF applications, a transfer trip scheme may be required. The AES/QF will remain separated until the Cooperative's electric system returns to its normal operating status for a specified minimum amount of time. The AES/QF will synchronize with the Cooperative's electric system only when the Cooperative electric facilities' voltage and frequency are within acceptable industry tolerances. Adherence to IEEE 1547-2017 relaying guidelines is required.

The AES/QF electric system should be able to withstand all expected electric transients that occur on Cooperative's electric distribution and transmission systems, including outages. For instance, fuse coordination and operation of Cooperative reclosers, single-phase or three-phase, should not cause damage that would require repair of the AES/QF's electric system. The AES/QF Owner shall have the sole responsibility for the safety and electrical protection of his/her AES/QF, without regard to the condition of the Cooperative's or Allegheny's facilities.

- D. The interconnection equipment must include an approved manual, visible load break safety switch lockable in the open position and be accessible at all time to the Cooperative's personnel. The AES/QF Owner shall agree that the Cooperative may open the disconnect switch without prior notice for the following reasons:
1. Emergency conditions on the Cooperative's system.
 2. Inspection of the AES/QF by the Cooperative reveals a hazardous condition or lack of proper maintenance of AES/QF facilities.
 3. The AES/QF interferes with electric service to Cooperative members or with the Cooperative's electric system. Interference may include, but not be limited to, over or under voltage or frequency, harmonics, etc.
 4. Repair work on the Cooperative's system. Where time permits, the Cooperative will attempt to provide advance notice to the AES/QF Owner of imminent disconnection of the AES/QF and the reasons for same.

- E. The AES/QF must be operated so that no adverse effect(s) or power quality issue(s) occur to the Cooperative's electric system or to others connected thereto. If such adverse effect(s) occur, the AES/QF Owner must discontinue operation of the AES/QF and take corrective action(s) at the AES/QF Owner's sole expense, as deemed necessary by the Cooperative, and/or industry standards, including IEEE 1547-2017, IEEE 929-2000, and UL 1741-2010. Adverse effect(s) and power quality issues include, but are not limited to, voltage regulation flicker, power factor and/or harmonics.
- F. The AES/QF Owner must inform the Cooperative of any changes to the AES/QF and obtain the Cooperative's approval, in writing, before changes are made to the AES/QF in order to address the adverse effect(s) referred to in Paragraph D above. Prior to reconnecting, the AES/QF Owner must inform the Cooperative of its intent to reconnect.
- G. The AES/QF Owner will own, install and maintain at his/her expense, all safety and interconnection equipment as specified by the Cooperative. Minimum required interconnection facilities are described in Section B hereto. The Cooperative reserves the right to observe and witness the installation and testing of interconnection facilities pursuant to industry practices, codes, and IEEE 1547-2017, IEEE 929-2000, and UL 1741-2010. Cooperative observation, review, inspection, or testing shall not be considered either as an endorsement or confirmation of any aspect, feature, element, or condition of the AES/QF or associated interconnection equipment or the operation thereof, nor as a warranty as to the fitness, safety, desirability, or reliability of same. The inspection does not impose any obligation upon the Cooperative or Allegheny to warrant or ensure in any manner the AES/QF's safety or compliance with this Agreement. Further, the Cooperative and Allegheny made no representations concerning, and expressly disclaim any expertise or specialized knowledge relating to the particular type of generation employed by the Generator or the equipment associated with such generation.
- H. The AES/QF must be installed to meet the C2-2017 National Electrical Safety Code (NESC) or other applicable code requirements for clearances from the nearest Cooperative electric facility, or such other distance as the Cooperative deems necessary for safety or electric operation-related reasons.
- I. The Cooperative or Allegheny reserves the right to inspect the AES/QF, interconnection equipment and associated maintenance records at any time. Such inspections shall not relieve the AES/QF

Owner from his/her obligation to operate and maintain the AES/QF in a safe and satisfactory manner.

- J. Except for residential consumer-members, the AES/QF Owner must have a current liability insurance policy adequate in amount to cover all forms of liability that may arise from the operation of the AES/QF interconnected to the Cooperative's electric system and the policy should list the Cooperative and Allegheny as additional names insured's. A copy of this policy must be on file with the Cooperative and Allegheny. Lapse of the policy must be automatically reported to the Cooperative and Allegheny by the insurer, and shall result in the immediate disconnection of the AES/QF from the Cooperative's electric system. In general, a minimum of \$1 million in liability insurance is suggested, but a more specific amount can be based on the Cooperative's review of the specific AES/QF. Residential consumer-members that are AES/QF Owners are encouraged to maintain a current liability insurance policy adequate in amount to cover all forms of liability that may arise from the interconnection of the AES/QF interconnected to the Cooperative's electric system. The owner or operator of the AES/QF shall pay all costs of changes for safety purposes or repairs or losses due to adverse effects on the equipment or facilities of other consumer-members or the Cooperative itself caused by the connection or operation of an AES/QF.
- K. The AES/QF Owner shall agree to hold the Cooperative and/or Allegheny harmless and indemnify the Cooperative and/or Allegheny in connection with any damages or injury affecting any party, resulting from the installation or the interconnection of the AES/QF to the Cooperative's or Allegheny's system, and the purchase of any output from the AES/QF, or operation of the AES/QF. The AES/QF Owner agrees to indemnify the Cooperative and/or Allegheny for any money damages, liabilities, administrative, and/or legal expenses incurred by the Cooperative and/or Allegheny as a result of the failure of the AES/QF Owner's equipment to meeting any requirement or condition set forth herein.
- L. The AES/QF Owner shall sell its output to Allegheny, pursuant to PURPA or ACT 213-2004 (as applicable) requirements, or upon written notification to Allegheny, to another entity. If another power purchasing entity is selected, a transmission or other charge may apply to wheel or transport the electric power over the Cooperative's or Allegheny's electric facilities. The Cooperative will sell electric energy and capacity to the AES/QF at rates and upon terms and conditions as specified in the Cooperative's applicable rules, regulations, policies, and rate schedules.

- M. The AES/QF Owner is responsible for executing a contract with Allegheny to receive compensation for its output delivered into the Cooperative's electric system. At the end of each annual period, Allegheny shall compensate the AES for kilowatt-hours generated by the AES over the amount of kilowatt-hours billed by the Cooperative during the annual period at Allegheny's avoided cost of wholesale power. KWH amounts less than 10% of annual usage will not be compensated by Allegheny but will remain for future credit.
- N. For AES/QF's of 500 kW or less, the AES/QF will be compensated at Allegheny's avoided cost rate. Net metering is available for residential generators up to 25 kW and non-residential accounts up to 150 kW. There is a \$100 net metering application fee.
- O. For AES/QF facilities of more than 500 kW, Allegheny will evaluate the proposed facility and negotiate potential purchase rates, administrative fees and other related costs to prevent intra system cost shifting. Allegheny's purchase of facility output will be based on: (1) Allegheny's avoided costs for contracts with terms of one year or less; or (2) negotiated pricing for contracts with longer terms. If a net metered generator with more than 500 kW in capacity produces generation that results in a 10% or greater reduction in the member's purchase of electricity from the Cooperative compared to the year immediately preceding the interconnection then the member shall be responsible for its share of stranded costs obligation as determined by the Cooperative.
- P. Allegheny may refuse to purchase output from an AES/QF from time-to-time so the Cooperative can: (1) construct, install, maintain, repair, replace, remove, investigate, or inspect any of the Cooperative's equipment or any part of the Cooperative's System; or (2) if the Cooperative and/or Allegheny determine(s) that curtailment, interruption, or reduction of deliveries of energy or energy and capacity is appropriate because of emergencies, forced outages, operating conditions on the Cooperative's system, or as otherwise required by industry standard electric practices.
- Q. Synchronous Generators will operate at a power factor required by the Cooperative.

III. RESPONSIBILITY

It shall be the responsibility of the Chief Executive Officer to implement this policy.

IV. This policy supersedes and cancels all other policies which relate to the subject matter herein and which may be in conflict herewith.

Date
adopted: October 17, 2013

Attest: Walter E. Botsford, Secretary

Revised: February 15, 2018
May 17, 2018
February 20, 2020
April 15, 2021
June 17, 2021

Kathy A. Robbins, Secretary
Kathy A. Robbins, Secretary
Kathy A. Robbins, Secretary
Kathy A. Robbins, Secretary

Kathy A. Robbins, Secretary

EXHIBIT 1

GENERAL PROTECTION REQUIREMENTS

Figure

- 1 Protection for a three-phase synchronous generator
- 2 Protection for a single-phase induction generator
- 3 Protection for a three-phase induction generator
- 4 Protection for a single-phase inverter
- 5 Protection for a three-phase inverter

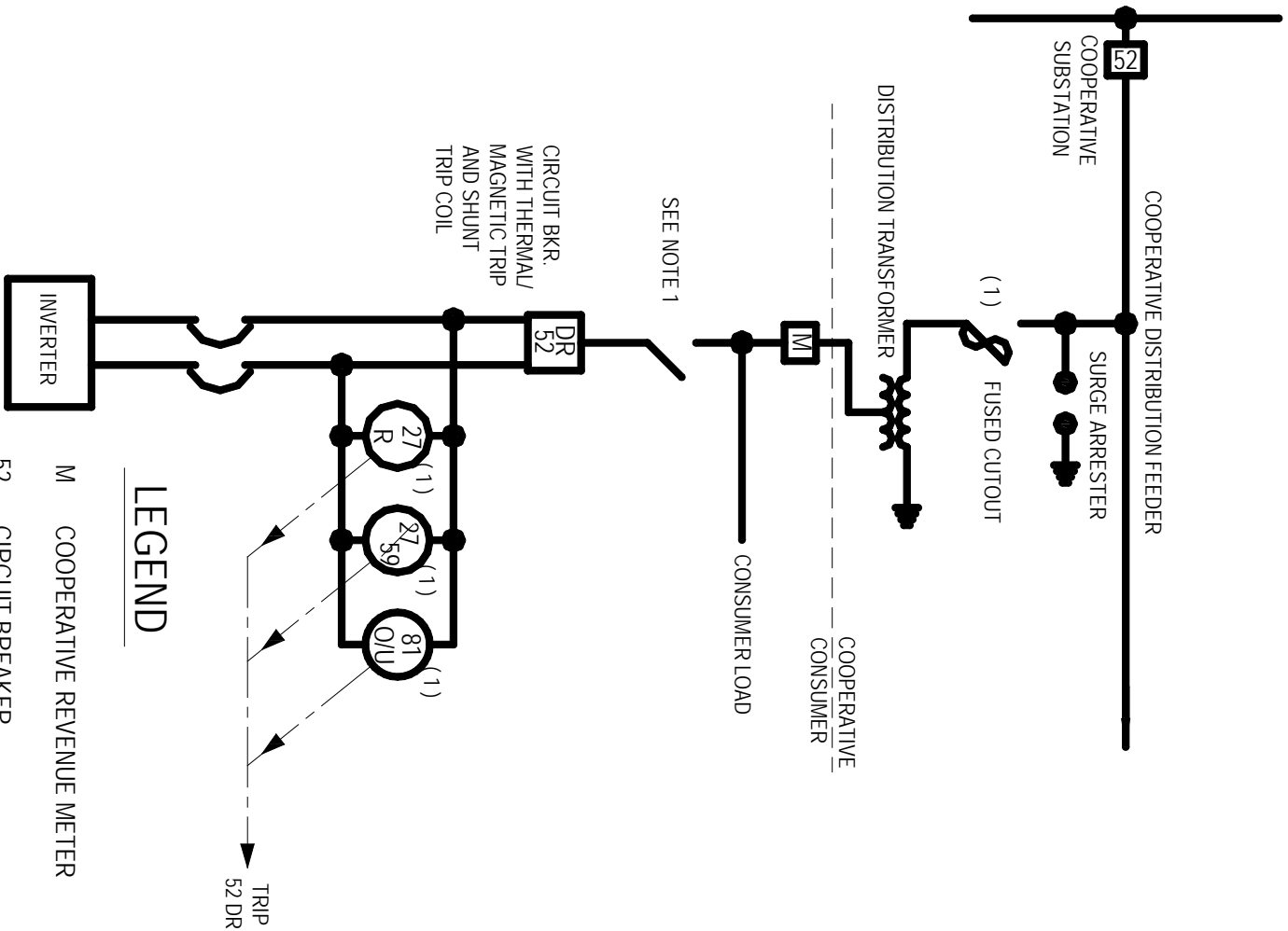

LEGEND

- M COOPERATIVE REVENUE METER
- 52 CIRCUIT BREAKER
- 27R INSTANTANEOUS UNDERVOLTAGE RELAY
- 27/59 TIME UNDER/OVER VOLTAGE RELAY
- 81 O/U OVER/UNDER FREQUENCY RELAY

NOTE:

1. SWITCH MUST BE PADLOCKABLE AND AVAILABLE TO THE COOPERATIVE AT ALL TIMES

Revisions
RFG 1/9/06

ALLEGHENY ELECTRIC COOPERATIVE

Harrisburg, Pennsylvania

Drawn: DRF

Checked: _____

Approved: BH

Date: 11-03-05

TYPICAL PROTECTION
EXAMPLE FOR SINGLE
PHASE INVERTER

Dwg. No. CCS - IPD - 01

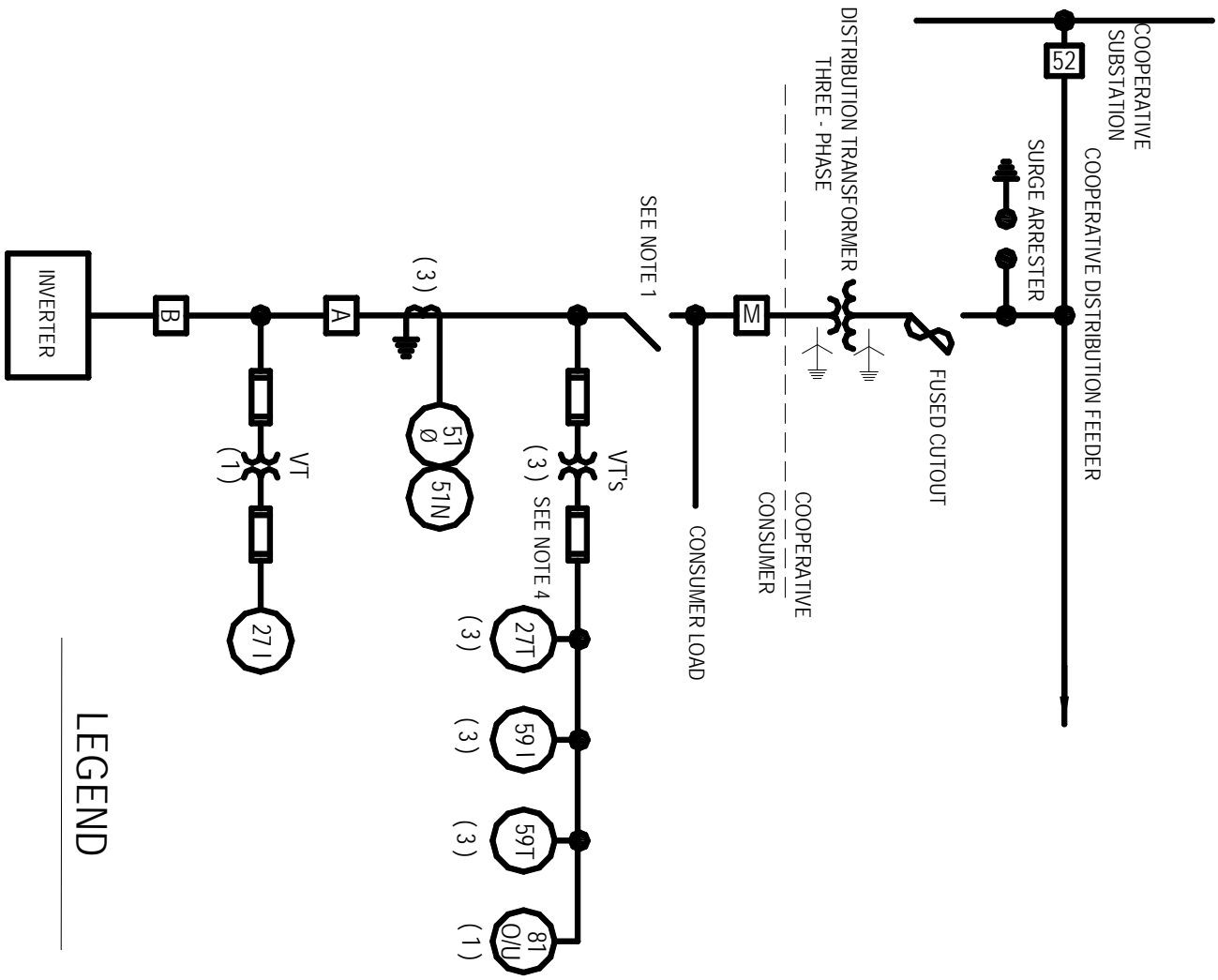

- NOTE:
1. SWITCH MUST BE PADLOCKABLE AND AVAILABLE TO THE COOPERATIVE AT ALL TIMES
 2. ALL PROTECTIVE RELAYING TRIPS BREAKER A
 3. SOURCE BEHIND INVERTER CAN BE BATTERY, FUEL CELL, PV OR OTHER DC SOURCE, POWER CONDITIONING SHOULD BE DONE BEFORE INVERTER
 4. IF GENERATION IS LESS THAN 100 KW USE ONE EACH OF 27T, 591, 59T AND ONE VT

271	INSTANTANEOUS UNDERVOLTAGE
27T	TIME UNDERVOLTAGE
51	TIME OVERCURRENT - PHASE
51N	TIME OVERCURRENT - GROUND
52	CIRCUIT BREAKER
591	INSTANTANEOUS OVERVOLTAGE
59T	TIME OVERVOLTAGE
81 O/U	OVER / UNDER FREQUENCY
M	COOPERATIVE REVENUE METER

LEGEND

TYPICAL PROTECTION
EXAMPLE FOR 3 - PHASE
INVERTER WITH WYE GROUND -
WYE GROUND TRANSFORMER

Dwg. No. CCS - IPD - 02

Drawn: DRF
Checked: _____
Approved: BH
Date: 11-03-05

ALLEGHENY ELECTRIC COOPERATIVE
Harrisburg, Pennsylvania

Revisions
RFG 1/9/06

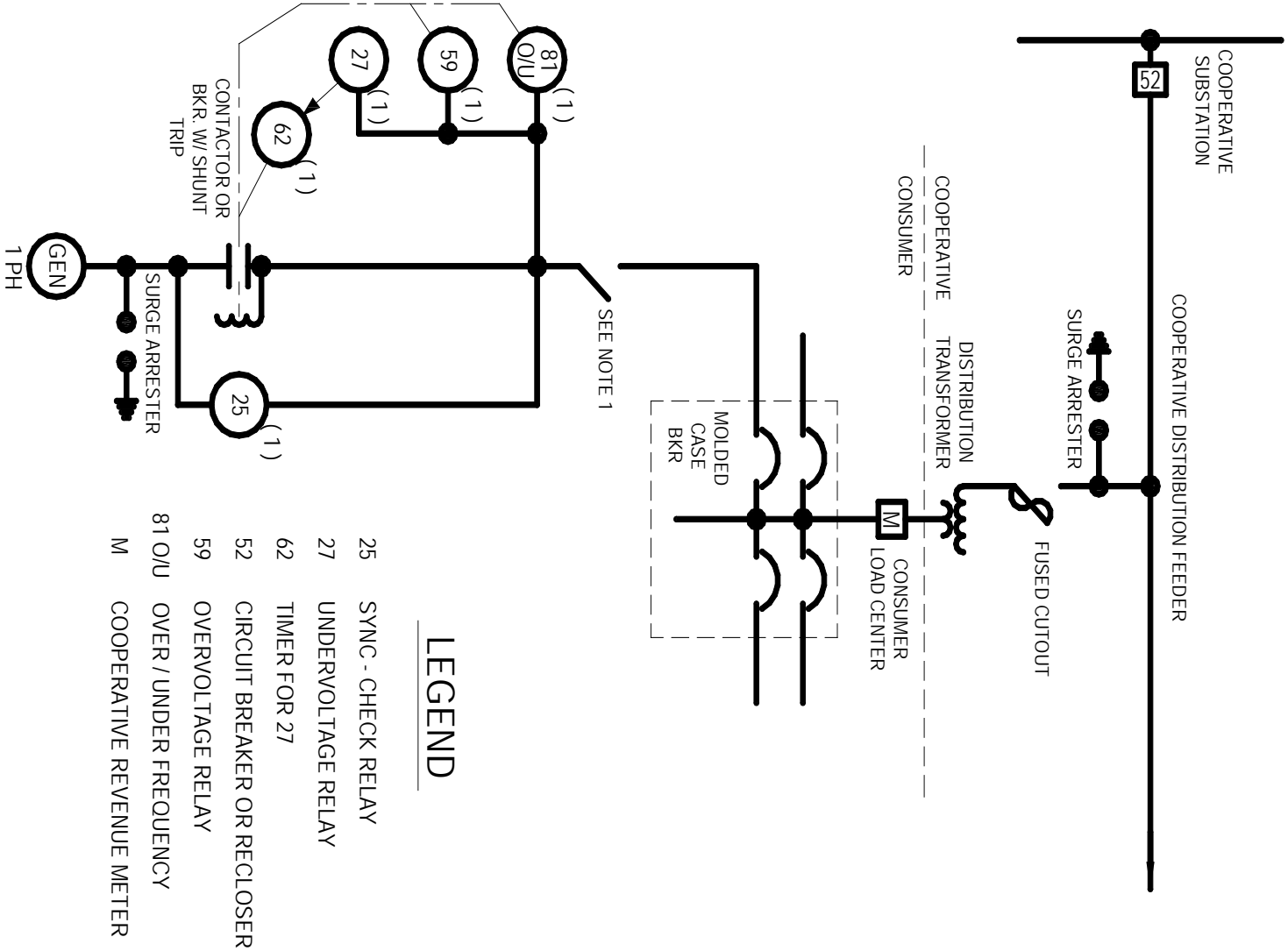

LEGEND

- 25 SYNC - CHECK RELAY
- 27 UNDERVOLTAGE RELAY
- 62 TIMER FOR 27
- 52 CIRCUIT BREAKER OR RECLOSER
- 59 OVERVOLTAGE RELAY
- 81 O/U OVER / UNDER FREQUENCY
- M COOPERATIVE REVENUE METER

NOTE:

1. SWITCH MUST BE PADLOCKABLE AND AVAILABLE TO THE COOPERATIVE AT ALL TIMES

Revisions
RFG 1/9/06

ALLEGHENY ELECTRIC COOPERATIVE

Harrisburg, Pennsylvania

Drawn: DRF
 Checked: _____
 Approved: BH
 Date: 11-03-05

TYPICAL PROTECTION
 EXAMPLE FOR SINGLE PHASE
 INDUCTION GENERATOR

Dwg. No. CCS - IPD - 03

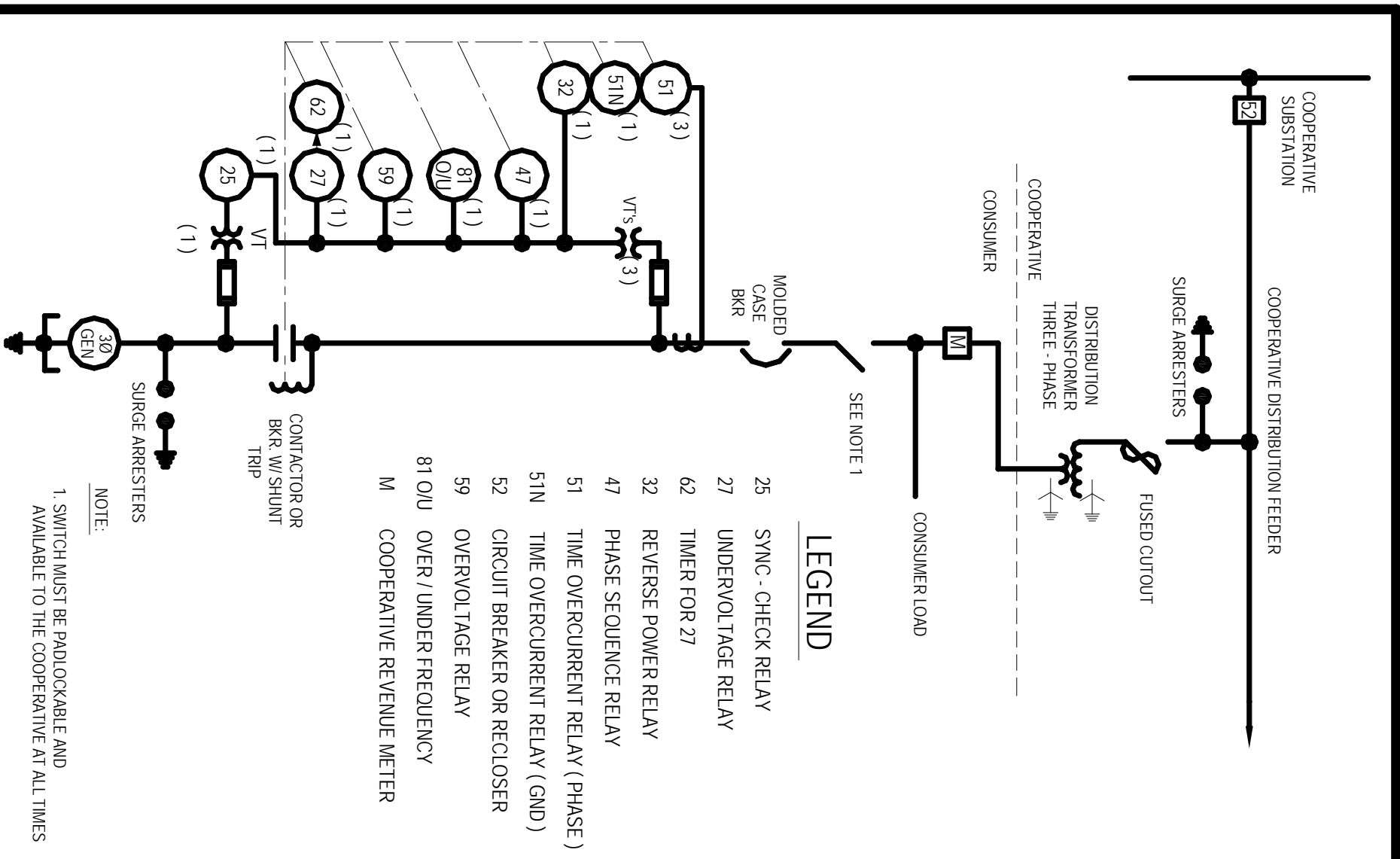

LEGEND

- 25 SYNC - CHECK RELAY
- 27 UNDERVOLTAGE RELAY
- 62 TIMER FOR 27
- 32 REVERSE POWER RELAY
- 47 PHASE SEQUENCE RELAY
- 51 TIME OVERCURRENT RELAY (PHASE)
- 51N TIME OVERCURRENT RELAY (GND)
- 52 CIRCUIT BREAKER OR RECLOSER
- 59 OVERVOLTAGE RELAY
- 81 O/U OVER / UNDER FREQUENCY
- M COOPERATIVE REVENUE METER

NOTE:

1. SWITCH MUST BE PADLOCKABLE AND AVAILABLE TO THE COOPERATIVE AT ALL TIMES

Revisions
RFG 1/9/06

ALLEGHENY ELECTRIC COOPERATIVE

Harrisburg, Pennsylvania

Drawn: DRF
 Checked: _____
 Approved: BH
 Date: 11-03-05

TYPICAL PROTECTION
 EXAMPLE FOR THREE - PHASE
 INDUCTION GENERATOR

Dwg. No. CCS - IPD - 04

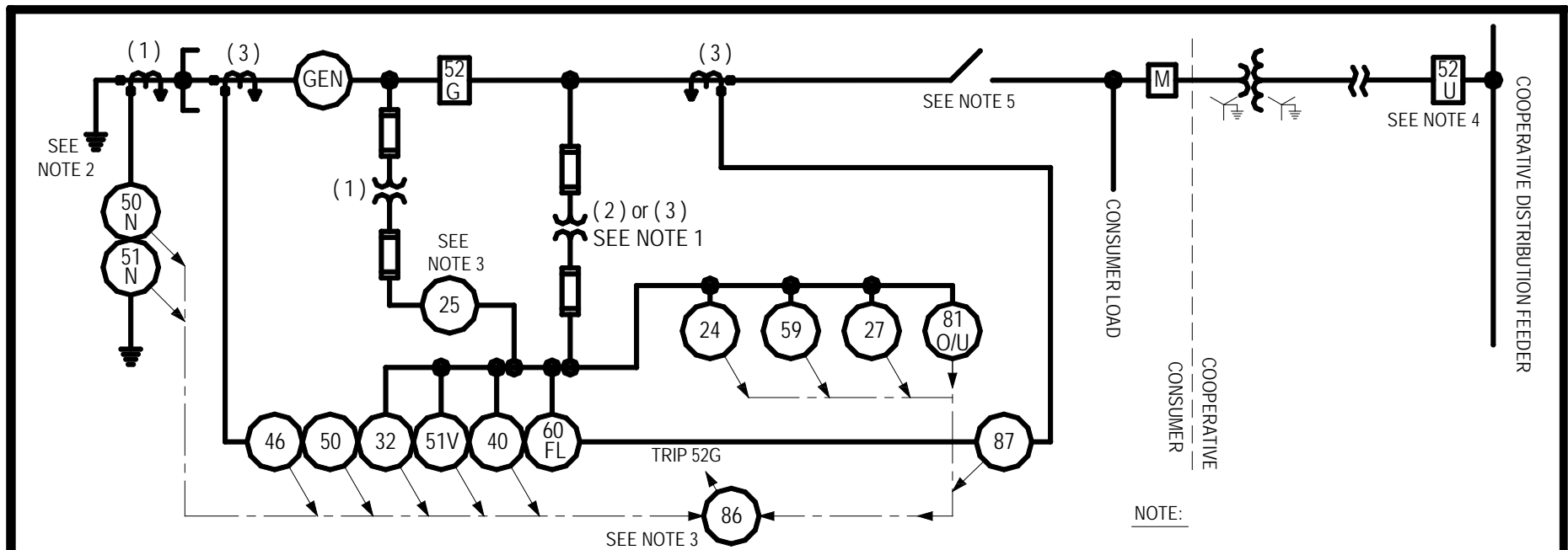

LEGEND

M	COOPERATIVE REVENUE METER	51N	TIME OVERCURRENT GROUND RELAY
PROTECTIVE RELAYS			
24	VOLTS / HZ RELAY	51V	VOLTAGE CONTROLLED TIME OVERCURRENT RELAY
27	UNDERVOLTAGE RELAY	59	OVERVOLTAGE RELAY
32	REVERSE POWER (ANTI - MOTORING) RELAY	60FL	FUSE LOSS DETECTION RELAY
40	LOSS OF FIELD RELAY	81 O/U	OVER / UNDER FREQUENCY RELAY
46	NEGATIVE SEQUENCE OVERCURRENT RELAY	86	LOCKOUT RELAY
50	INSTANTANEOUS OVERCURRENT RELAY	87	DIFFERENTIAL RELAY
50N	INSTANTANEOUS OVERCURRENT GROUND RELAY	CONTROL RELAYS :	
		25	AUTOMATIC SYNCHRONIZER OR SYNC - CHECK RELAY
		52	BREAKER

NOTE:

1. VT's CAN BE CONNECTED WYE OR OPEN DELTA
2. GENERATOR GROUNDING SHOWN IS LOW IMPEDANCE, HIGH IMPEDANCE GROUNDING CAN BE USED IF DESIRED
3. RELAYING DEVICES SHOWN ARE ALL PART OF A MULTI - FUNCTION RELAY EXCEPT FOR DEVICES 25 AND 86. FUNCTIONS CAN BE INCREASED OR DECREASED AS DICTATED BY THE PARTICULAR APPLICATION
4. IF 52U IS RECLOSING CIRCUIT BREAKER, RECLOSING SHOULD BE SUPERVISED BY A SYNC - CHECK RELAY (DEVICE 25)
5. SWITCH MUST BE PADLOCKABLE AND AVAILABLE TO THE COOPERATIVE AT ALL TIMES

Revisions
RFG 1/9/06

ALLEGHENY ELECTRIC COOPERATIVE
Harrisburg, Pennsylvania

Drawn: DRF
Checked: _____
Approved: BH
Date: 11-03-05

TYPICAL PROTECTION SCHEME
FOR SMALL SYNCHRONOUS GENERATOR
INDUCTION GENERATOR
< 1 MW

Dwg. No. CCS - IPD - 05